



# **H** TECHNICAL PROCEDURE

## COMFORT AIR® 10K Rear Air Suspension for ARBOC Specialty Vehicles

SUBJECT: Service Instructions

LIT NO: 17730-304

DATE: October 2016

REVISION: A

### TABLE OF CONTENTS

<b>Section 1</b>	<b>Introduction</b> . . . . .	2	<b>Section 8</b>	<b>Component Replacement</b>	
<b>Section 2</b>	<b>Product Description</b> . . . . .	2		Fasteners . . . . .	19
<b>Section 3</b>	<b>Important Safety Notice</b> . . . . .	4		Height Control Valve . . . . .	19
<b>Section 4</b>	<b>Parts Lists</b> . . . . .	8		Air Spring . . . . .	19
<b>Section 5</b>	<b>Special Tools</b> . . . . .	10		Shock Absorber . . . . .	20
<b>Section 6</b>	<b>Preventive Maintenance</b>			Shock Absorber Lower Mounting Bracket . . . . .	21
	Component Inspection . . . . .	11		Transverse Torque Rod . . . . .	21
	U-bolt Locknuts . . . . .	12		Torque Rod Bushing . . . . .	22
	Transverse Torque Rods . . . . .	13		Clamp Group – Top Pad & Lower Air Spring Bracket/Bottom Cap Assembly . . . . .	24
	Air Fitting Inspection . . . . .	14		Main Support Member . . . . .	26
	Shock Absorber . . . . .	14		Frame Hanger . . . . .	28
<b>Section 7</b>	<b>Alignment &amp; Adjustments</b>		<b>Section 9</b>	<b>Torque Specifications</b> . . . . .	30
	Lateral Alignment . . . . .	16	<b>Section 10</b>	<b>Troubleshooting Guide</b> . . . . .	32
	Pinion Angle . . . . .	17			
	Drive Axle Alignment Inspection . . . . .	17			

## SECTION 1

# Introduction

This publication is intended to acquaint and assist maintenance personnel in the preventive maintenance, service, repair, and rebuild for the COMFORT AIR® 10K single axle air suspension system as installed on applicable ARBOC Specialty Vehicles.

### NOTE

Use only Hendrickson Genuine Parts for servicing this suspension system.

It is important to read and understand the entire Technical Procedure publication prior to performing any maintenance, service, repair, or rebuild of this product. The information in this publication contains parts lists, safety information, product specifications, features, proper maintenance, service, repair and rebuild instructions for the COMFORT AIR Suspension.

Hendrickson reserves the right to make changes and improvements to its products and publications at any time. Contact Hendrickson Tech Services for information on the latest version of this manual at 1-866-755-5968 (toll-free U.S. and Canada), 1-630-910-2800 (outside U.S. and Canada) or e-mail: [techservices@hendrickson-intl.com](mailto:techservices@hendrickson-intl.com).

**The latest revision of this publication is also available online at [www.hendrickson-intl.com](http://www.hendrickson-intl.com).**

## SECTION 2

# Product Description

**FIGURE 2-1**

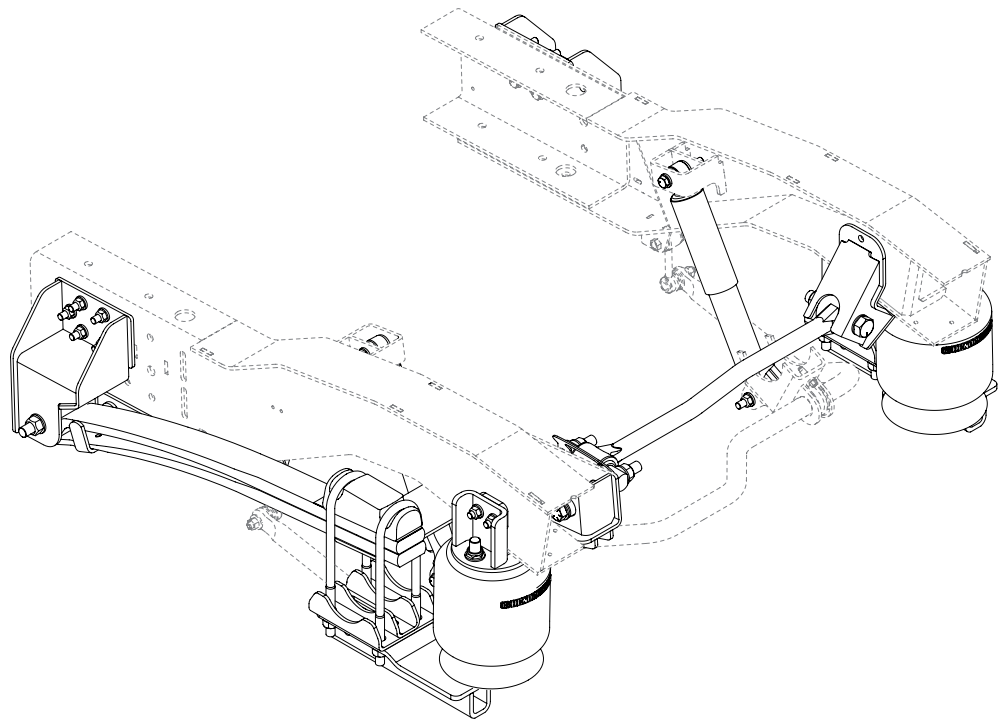



The **COMFORT AIR rear air suspension** is designed and manufactured specifically for the cut away and specialty vehicle market place. Available in a 10,000 pounds capacity ratings, COMFORT AIR offers a kneeling feature with minimal forward roll while maintaining stability and driver handling. Air springs and shocks work together to adjust to changing road conditions, providing passengers with a comfortable ride.

- **Air Springs** — Enhance passenger comfort. Positioned near the axle to transfer more load to the air springs and allow for smoother ride and less twist induced on the axle from main support member leaf springs.
- **Shocks** — Positioned and tuned for optimum damping characteristics.
- **Main Support Members** — Longer front limb length transfers less loads through the frame connection and reduces fatigue. Designed to reduce roll forward less than 1.5" during kneeling operation and achieve 3.5" of kneel.
- **Genuine Hendrickson Torque Rods** — Optimized configuration helps improve handling and roll stiffness. Control lateral forces to maintain axle position. Enhance handling during cornering.
- **Structural Components** — Provides over 8.2" ground clearance.

## COMFORT AIR 10K SPECIFICATIONS

<b>Suspension Capacity<sup>1</sup>:</b>	10,000 Pound
<b>Suspension Weight<sup>2</sup>:</b>	270 Pound
<b>GVW:</b>	10,000 Pound
<b>Ride Height:</b>	6.5" - 8.2"

All applications must comply with applicable Hendrickson specifications and must be approved by ARBOC Specialty Vehicles with the vehicle in its original, as-built configuration.

All marks are trademarks of their respective owners.

COMFORT AIR is approved for most bus, ambulance and motorhome applications.

1. COMFORT AIR is approved for up to 10 percent off-highway use.
2. The suspension weight includes the frame hanger brackets, main support member, axle clamp group, air springs, shock absorbers, upper and lower shock brackets, transverse torque rod and frame bracket and fasteners. Weight may vary slightly based upon application specific configuration.



## SECTION 3

# Important Safety Notice

Proper maintenance, service, and repair is important for the reliable operation of the suspension. The procedures recommended by Hendrickson and described in this technical publication are methods of performing such maintenance, service and repair.

All information should be read carefully to help prevent personal injury and to assure that proper methods are used. Improper maintenance, service or repair may damage the vehicle, cause personal injury, render it unsafe in operation, or void manufacturer's warranty.

Failure to follow the safety precautions in this manual can result in personal injury and/or property damage. Carefully read and understand all safety related information within this publication, on all decals and in all such materials provided by the vehicle manufacturer before conducting any maintenance, service or repair.

## ■ EXPLANATION OF SIGNAL WORDS

Hazard "Signal Words" (Danger-Warning-Caution) appear in various locations throughout this publication. Information accented by one of these signal words must be observed to help minimize the risk of personal injury to service personnel, or possibility of improper service methods which may damage the vehicle or render it unsafe.



This is the safety alert symbol. It is used to alert you to potential personal injury hazards. Obey all safety messages that follow this symbol to avoid possible injury or death.

Additional Notes or Service Hints are utilized to emphasize areas of procedural importance and provide suggestions for ease of repair. The following definitions indicate the use of these signal words as they appear throughout the publication.

**DANGER**

INDICATES AN IMMINENTLY HAZARDOUS SITUATION WHICH, IF NOT AVOIDED, WILL RESULT IN SERIOUS INJURY OR DEATH.

**WARNING**

INDICATES A POTENTIAL HAZARDOUS SITUATION WHICH, IF NOT AVOIDED, COULD RESULT IN SERIOUS INJURY OR DEATH.

**CAUTION**

INDICATES A POTENTIAL HAZARDOUS SITUATION WHICH, IF NOT AVOIDED, MAY RESULT IN MINOR OR MODERATE INJURY, OR PROPERTY DAMAGE.

**NOTE**

An operating procedure, practice condition, etc., which is essential to emphasize.

**SERVICE HINT**

A helpful suggestion that will make the servicing being performed a little easier and/or faster.

Also note that particular service operations may require the use of special tools designed for specific purposes. These special tools can be found in the Special Tools Section of this publication.



The torque symbol alerts you to tighten fasteners to a specified torque value. Refer to Torque Specifications Section of this publication.



## ■ SAFETY PRECAUTIONS

### WARNING

#### **FASTENERS**

DISCARD USED FASTENERS. ALWAYS USE NEW FASTENERS TO COMPLETE A REPAIR. FAILURE TO DO SO COULD RESULT IN FAILURE OF THE PART, OR MATING COMPONENTS, LOSS OF VEHICLE CONTROL, PERSONAL INJURY, OR PROPERTY DAMAGE.

LOOSE OR OVER TORQUED FASTENERS CAN CAUSE COMPONENT DAMAGE, LOSS OF VEHICLE CONTROL, PROPERTY DAMAGE, OR SEVERE PERSONAL INJURY. MAINTAIN CORRECT TORQUE VALUE AT ALL TIMES. CHECK TORQUE VALUES ON A REGULAR BASIS AS SPECIFIED, USING A PROPER TORQUE WRENCH THAT IS REGULARLY CALIBRATED. TORQUE VALUES SPECIFIED IN THIS TECHNICAL PUBLICATION ARE FOR HENDRICKSON SUPPLIED FASTENERS ONLY. IF NON HENDRICKSON FASTENERS ARE USED, FOLLOW TORQUE SPECIFICATION LISTED IN THE VEHICLE MANUFACTURER'S SERVICE MANUAL.

### WARNING

#### **LOAD CAPACITY**

ADHERE TO THE PUBLISHED CAPACITY RATINGS FOR THE SUSPENSION. ADD-ON AXLE ATTACHMENTS AND OTHER LOAD TRANSFERRING DEVICES, SUCH AS LIFTABLE AXLES, CAN INCREASE THE SUSPENSION LOAD ABOVE ITS RATED AND APPROVED CAPACITIES, WHICH CAN RESULT IN COMPONENT DAMAGE AND LOSS OF VEHICLE CONTROL, POSSIBLY CAUSING PERSONAL INJURY OR PROPERTY DAMAGE.

### WARNING

#### **MODIFYING COMPONENTS**

DO NOT MODIFY OR REWORK PARTS WITHOUT AUTHORIZATION FROM HENDRICKSON. DO NOT SUBSTITUTE REPLACEMENT COMPONENTS NOT AUTHORIZED BY HENDRICKSON. USE OF MODIFIED, REWORKED, SUBSTITUTE OR REPLACEMENT PARTS NOT AUTHORIZED BY HENDRICKSON MAY NOT MEET HENDRICKSON'S SPECIFICATIONS, AND CAN RESULT IN FAILURE OF THE PART, LOSS OF VEHICLE CONTROL, POSSIBLE PERSONAL INJURY OR PROPERTY DAMAGE, AND WILL VOID WARRANTY. USE ONLY HENDRICKSON AUTHORIZED REPLACEMENT PARTS.

### WARNING

#### **TORCH/WELDING**

DO NOT USE A CUTTING TORCH TO REMOVE ANY FASTENERS. THE USE OF HEAT ON SUSPENSION COMPONENTS WILL ADVERSELY AFFECT THE STRENGTH OF THESE PARTS. A COMPONENT DAMAGED IN THIS MANNER CAN RESULT IN THE LOSS OF VEHICLE CONTROL AND POSSIBLE PERSONAL INJURY OR PROPERTY DAMAGE. EXERCISE EXTREME CARE WHEN HANDLING OR PERFORMING MAINTENANCE IN THE AREA OF THE MAIN SUPPORT MEMBER. DO NOT CONNECT ARC WELDING GROUND LINE TO THE MAIN SUPPORT MEMBER. DO NOT STRIKE AN ARC WITH THE ELECTRODE ON THE MAIN SUPPORT MEMBER. DO NOT USE HEAT NEAR THE MAIN SUPPORT MEMBER. DO NOT NICK OR GOUGE THE MAIN SUPPORT MEMBER. SUCH IMPROPER ACTIONS CAN DAMAGE THE MAIN SUPPORT MEMBER AND CAUSE LOSS OF VEHICLE CONTROL AND POSSIBLE PERSONAL INJURY OR PROPERTY DAMAGE.

### CAUTION

#### **PROCEDURES AND TOOLS**

A TECHNICIAN USING A SERVICE PROCEDURE OR TOOL WHICH HAS NOT BEEN RECOMMENDED BY HENDRICKSON MUST FIRST SATISFY HIMSELF THAT NEITHER HIS SAFETY NOR THE VEHICLE'S SAFETY WILL BE JEOPARDIZED BY THE METHOD OR TOOL SELECTED. INDIVIDUALS DEVIATING IN ANY MANNER FROM THE INSTRUCTIONS PROVIDED WILL ASSUME ALL RISKS OF CONSEQUENTIAL PERSONAL INJURY OR DAMAGE TO EQUIPMENT INVOLVED.

### WARNING

#### **SHOCK ABSORBERS**

THE SHOCK ABSORBERS ARE THE REBOUND TRAVEL STOPS FOR THE SUSPENSION. ANYTIME THE AXLE ON A COMFORT AIR SUSPENSION IS SUSPENDED IT IS MANDATORY THAT THE SHOCK ABSORBERS REMAIN CONNECTED. FAILURE TO DO SO CAN CAUSE THE AIR SPRINGS TO SEPARATE FROM THE PISTON AND RESULT IN PREMATURE AIR SPRING FAILURE. REPLACEMENT OF SHOCK ABSORBERS WITH NON-HENDRICKSON PARTS CAN ALTER THE REBOUND TRAVEL OF THE SUSPENSION.

**⚠ WARNING****PERSONAL PROTECTIVE EQUIPMENT**

ALWAYS WEAR PROPER EYE PROTECTION AND OTHER REQUIRED PERSONAL PROTECTIVE EQUIPMENT TO HELP PREVENT PERSONAL INJURY WHEN PERFORMING VEHICLE MAINTENANCE, REPAIR OR SERVICE.

**⚠ WARNING****AIR SPRING INFLATION AND DEFLATION**

PRIOR TO DISASSEMBLY OF THE SUSPENSION, AIR SPRING ASSEMBLIES MUST BE DEFLATED. UNRESTRICTED AIR SPRING ASSEMBLIES CAN VIOLENTLY SHIFT. DO NOT INFLATE AIR SPRING ASSEMBLIES WHEN THEY ARE UNRESTRICTED. AIR SPRING ASSEMBLIES MUST BE RESTRICTED BY SUSPENSION OR OTHER ADEQUATE STRUCTURE. DO NOT INFLATE BEYOND PRESSURES RECOMMENDED BY AIR SPRING MANUFACTURER, CONTACT HENDRICKSON TECHNICAL SERVICES FOR DETAILS. IMPROPER USE OR OVER INFLATION MAY CAUSE AIR SPRING ASSEMBLIES TO BURST, CAUSING PROPERTY DAMAGE AND/OR SEVERE PERSONAL INJURY.

**⚠ WARNING**

PRIOR TO AND DURING DEFLATION AND INFLATION OF THE AIR SUSPENSION SYSTEM, ENSURE ALL PERSONNEL AND EQUIPMENT ARE CLEAR FROM UNDER THE VEHICLE AND AROUND THE SERVICE AREA, FAILURE TO DO SO CAN CAUSE SERIOUS PERSONAL INJURY, DEATH, OR PROPERTY DAMAGE.

**⚠ CAUTION****AIR SPRING INFLATION**

INFLATE THE SUSPENSION SLOWLY AND MAKE SURE THE RUBBER BLADDER OF THE AIR SPRING INFLATES UNIFORMLY AND IS NOT BINDING. FAILURE TO DO SO CAN CAUSE DAMAGE TO THE AIR SPRING AND/OR MOUNTING BRACKETS AND VOID WARRANTY.

**⚠ CAUTION****AIR SPRING LOWER MOUNTING STUDS**

IF THE AIR SPRING IS BEING REMOVED FOR AN ALTERNATE REPAIR, IT IS MANDATORY TO LUBRICATE THE LOWER AIR SPRING FASTENERS WITH PENETRATING OIL AND REMOVE WITH HAND TOOLS TO PREVENT DAMAGE TO THE LOWER AIR SPRING MOUNTING STUD. FAILURE TO DO SO CAN CAUSE COMPONENT DAMAGE AND VOID WARRANTY.

**⚠ WARNING****PARTS CLEANING**

SOLVENT CLEANERS CAN BE FLAMMABLE, POISONOUS, AND CAUSE BURNS. TO HELP AVOID SERIOUS PERSONAL INJURY, CAREFULLY FOLLOW THE MANUFACTURER'S PRODUCT INSTRUCTIONS AND GUIDELINES AND THE FOLLOWING PROCEDURES:

1. WEAR PROPER EYE PROTECTION.
2. WEAR CLOTHING THAT PROTECTS YOUR SKIN.
3. WORK IN A WELL-VENTILATED AREA.
4. DO NOT USE GASOLINE OR SOLVENTS THAT CONTAIN GASOLINE. GASOLINE CAN EXPLODE.
5. HOT SOLUTION TANKS OR ALKALINE SOLUTIONS MUST BE USED CORRECTLY. FOLLOW THE MANUFACTURER'S RECOMMENDED INSTRUCTIONS AND GUIDELINES CAREFULLY TO HELP PREVENT PERSONAL ACCIDENT OR INJURY.

DO NOT USE HOT SOLUTION TANKS OR WATER AND ALKALINE SOLUTIONS TO CLEAN GROUND OR POLISHED PARTS. DOING SO WILL CAUSE DAMAGE TO THE PARTS AND VOID WARRANTY.

**⚠ WARNING****TRANSVERSE RODS**

THE COMFORT AIR SUSPENSION INCORPORATES TRANSVERSE RODS FOR VEHICLE STABILITY. IF THESE COMPONENTS ARE DISCONNECTED OR ARE NON-FUNCTIONAL THE VEHICLE SHOULD NOT BE OPERATED. FAILURE TO DO SO CAN RESULT IN ADVERSE VEHICLE HANDLING, LOSS OF VEHICLE CONTROL, SEVERE PERSONAL INJURY, AND PREMATURE COMPONENT DAMAGE, AND POSSIBLE TIRE CONTACT WITH THE FRAME.



 **WARNING**

**U-BOLT FASTENERS**

U-BOLTS THAT ARE FOUND TO BE LOOSE REQUIRE THAT MATING COMPONENTS BE INSPECTED FOR SIGNS OF WEAR. ANY WORN COMPONENTS MUST BE REPLACED. FAILURE TO DO SO CAN CAUSE PREMATURE CLAMP GROUP FAILURE, COMPONENT DAMAGE, LOSS OF VEHICLE CONTROL, PROPERTY DAMAGE, OR SEVERE PERSONAL INJURY. MAINTAIN CORRECT TORQUE VALUES AT ALL TIMES. CHECK TORQUE VALUES ON A REGULAR BASIS AS SPECIFIED.

 **WARNING**

**MAIN SUPPORT MEMBER**

FAILURE OF THE MAIN SUPPORT MEMBER BETWEEN THE U-BOLTS WILL REQUIRE THE REPLACEMENT OF THE MAIN SUPPORT MEMBER AND ALL CLAMP GROUP COMPONENTS. FAILURE TO DO SO CAN RESULT IN CLAMP GROUP FAILURE AND FURTHER FAILURE OF THE MAIN SUPPORT MEMBER, WHICH CAN CAUSE LOSS OF VEHICLE CONTROL, PROPERTY DAMAGE OR SEVERE PERSONAL INJURY.

# SECTION 4 Parts Lists

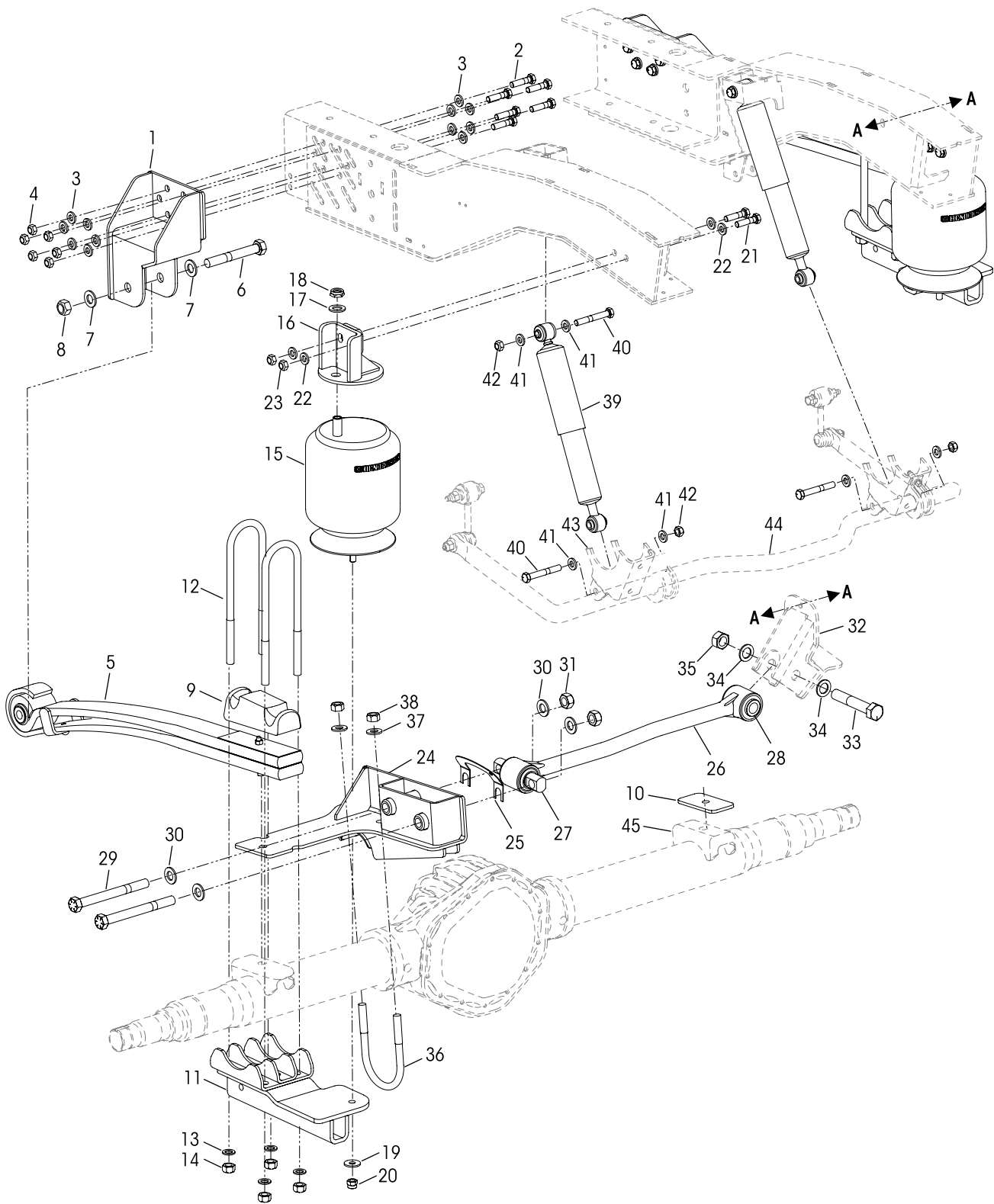





# COMFORT AIR® 10K for ARBOC Specialty Vehicles

KEY NO.	PART NO.	DESCRIPTION	VEHICLE QTY.	KEY NO.	PART NO.	DESCRIPTION	VEHICLE QTY.
1		Frame Hanger		20	17700-010	½"-13 UNC-2B Locknut	2
	79373-001	Left Hand	1	21	24531-006	½"-13 UNC x 2" Hex Bolt	4
	79373-002	Right Hand	1	22	22962-014	½" Flat Washer	8
	34013-221	<b>Frame Hanger Fasteners Service Kit, One Side,</b> Includes Key Nos. 2-4		23	49846-000	½"-13 UNC Locknut	4
2	24531-006	½"-13 UNC x 2" Hex Bolt	12	24	78837-000	LH Transverse Torque Rod Axle Mount Assembly	1
3	22962-014	½" Flat Washer	24	25	49689-000	Torque Rod Shim	2
4	49846-000	½"-13 UNC Locknut	12	26	79320-630	Torque Rod Assembly	1
5	53982-000	Main Support Member	2	27	69210-000L	Straddle Bushing	1
	34013-222	<b>Main Support Member Spring Eye Fasteners Service Kit, One Side,</b> Includes Key Nos. 6-8		28	47692-000	Thru Hole Bushing	1
6	21867-026	¾"-16 UNF x 5½" Hex Bolt	2			<b>Torque Rod Fasteners Service Kits</b>	
7	22962-047	¾" Flat Washer	4		34013-224	To Axle Mount, Includes Key Nos. 25, 29-31	
8	30191-000	¾"-16 UNF-2B Locknut	2		34013-223	To Frame Mount, Includes Key Nos. 33-35	
9	79307-001	Top Pad	2	29	21867-003	¾"-16 UNF x 7½" Hex Bolt	2
10	79306-001	Right Spring Seat Spacer	1	30	22962-047	¾" Flat Washer	4
11		Lower Air Spring Bracket / Bottom Cap Assembly		31	30191-000	¾"-16 UNF-2B Locknut	2
	78830-001	Left Hand	1	32		**Transverse Torque Rod Frame Mount	1
	78830-002	Right Hand	1	33	30418-011	7/8"-14 UNF x 5" Hex Bolt	1
	34013-220	<b>Clamp Group U-bolt Fasteners Service Kit, One Side,</b> Includes Key Nos. 12-14		34	22962-055	7/8" Flat Washer	2
12	79321-001	5/8"-18 UNF-2A x 12" U-bolt	4	35	04842-000	7/8"-14 UNF-2B Locknut	1
13	22962-025	5/8" Flat Washer	8		34013-225	<b>U-bolt to Axle Mount Fasteners Service Kit,</b> Includes Key Nos. 36-38	
14	66897-000	5/8"-18 UNF-2B Hex Nut	8	36	79322-001	5/8"-18 UNF-2A x 6½" U-bolt	1
	34013-227	<b>Air Spring Service Kit, One Side,</b> Includes Key Nos. 14, 17-20		37	22962-004	5/8" Flat Washer	2
15	78824-000	Air Spring Assembly	2	38	66897-000	5/8"-18 UNF-2B Hex Nut	2
16		Upper Air Spring Bracket Assembly			34013-226	<b>Shock Absorber Fasteners Service Kit, One Side,</b> Includes Key Nos. 39-42	
	78845-001	Left Hand	1	39	79333-001	Shock Absorber	2
	78845-002	Right Hand	1	40	24531-016	½"-13 UNC x 3½" Hex Bolt	4
	22962-001	¾" Flat Washer	2	41	22962-014	½" Flat Washer	8
17	17700-031	¾"-16 UNF-2B Locknut	2	42	49846-000	½"-13 UNC Locknut	4
18	22962-031	½" Flat Washer	2	43		**Lower Shock Absorber Bracket	2
19				44		**Swaybar	1
				45		**Axle Tube and Spring Seats	1

## NOTE

\* Item included in assembly/kit only, part not sold separately.

\*\* Not supplied by Hendrickson, used for reference only. Hendrickson is not responsible for components supplied by the vehicle manufacturer. For assistance with maintenance and rebuild instructions on these components see vehicle manufacturer.

## SECTION 5

# Special Tools

### TORQUE ROD BUSHING TOOLS – ULTRA ROD

These shop made tools are designed for servicing torque rod bushings. Bushing tools are to be made from cold rolled steel or equivalent. The drawings are for reference only, Hendrickson does not supply these tools.

#### RECEIVING TOOL

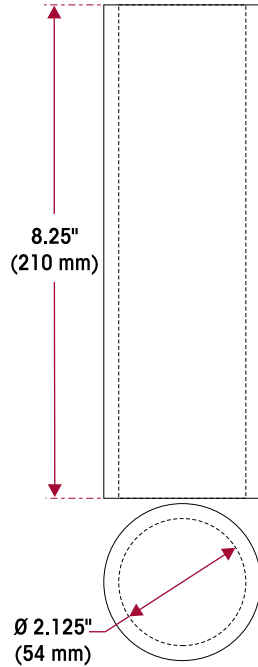

#### INSTALLATION / REMOVAL TOOL

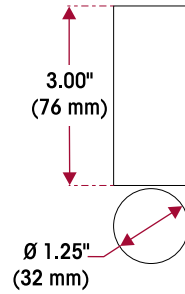

#### ULTRA ROD FUNNEL TOOL

Hendrickson Part No. 66086-001L





## SECTION 6

# Preventive Maintenance

Following appropriate inspection procedures is important to help ensure the proper maintenance and operation of the COMFORT AIR suspension system and component parts function to their highest efficiency. Look and replace any bent, cracked, worn or damaged parts.

### HENDRICKSON RECOMMENDED PREVENTIVE MAINTENANCE INTERVALS

- Preparation for delivery
- The first 1,000 miles
- On-highway – every 20,000 miles or every 6 months, whichever comes first

### COMPONENT INSPECTION

- **Air spring** – Look for chafing or any signs of spring or component damage. Ensure that the upper air spring bracket is tight against the underside of the frame. Check for any lateral slippage at the lower air spring bracket / bottom cap assembly. Replace all worn or damaged parts.
- **Clamp group** – Visually inspect for any loose or damaged fasteners. Verify the U-bolt locknuts have the proper torque values maintained. See the U-bolt Locknuts in this section.
- **Fasteners** – Look for any loose or damaged fasteners on the entire suspension. Make sure all fasteners are tightened to a torque value within the specified torque range. See Torque Specifications Section of this publication for recommended torque requirements. Use a calibrated torque wrench to check torque in a tightening direction. As soon as the fastener starts to move, record the torque. Correct the torque if necessary. Replace any worn or damaged fasteners with genuine specified fasteners.
- **Frame hanger bracket** – Check for cracks, damage, or any signs of looseness at the mounting fasteners. Replace all worn or damaged parts.
- **Main support member** – Look for signs of looseness, cracks, or other damage. Inspect bushings for looseness, torn or shredded rubber. Check torque on spring eye fasteners and U-bolts. Correct the torque if necessary. Replace all worn or damaged parts.
- **Shock absorbers** – Look for any signs of dents or leakage. Misting is not considered a leak, see Shock Absorber Inspection in this section.
- **Tire wear** – Inspect the tires for wear patterns that may indicate suspension damage or misalignment. Replace all worn or damaged parts.
- **Torque rods** – All torque rods must be inspected for looseness, torn or shredded rubber, and for proper torque. If there is metal-to-metal contact in the bushing joint, this is a sign of excessive bushing wear and the bushing needs to be replaced. Replace all worn or damaged parts.
- **Wear and damage** – Inspect all parts of the suspension for wear and damage. Look for and replace bent, cracked, or damaged parts.

See vehicle manufacturer's applicable publications for other preventive maintenance requirements.

## U-BOLT LOCKNUTS

### NOTE

Hendrickson Truck Suspension Systems U-bolt clamp group hardware for the COMFORT AIR suspension are phosphate and oil coated  $\frac{5}{8}$ "-18 UNF Grade 2B locknuts and  $\frac{5}{8}$ "-18 UNF Grade 8 U-bolts.

### WARNING

IT IS IMPORTANT THAT THE U-BOLT CLAMP GROUP CONNECTIONS BE PROPERLY ALIGNED AND HAVE THE PROPER TIGHTENING TORQUE VALUES MAINTAINED. METAL SURFACES CAN WORK AND WEAR AGAINST OTHER RELATED CLAMP GROUP COMPONENTS IF NOT PROPERLY ALIGNED OR PROPERLY TIGHTENED TO MAINTAIN THE PROPER CLAMP FORCE. FAILURE TO DO SO CAN CAUSE PREMATURE COMPONENT WEAR, POSSIBLE SEPARATION OF THE CLAMP GROUP, CAUSING LOSS OF VEHICLE CONTROL, PROPERTY DAMAGE, OR PERSONAL INJURY.

Maintaining the correct U-bolt torque value is important to help ensure proper suspension component performance.

- Inspect the U-bolts for proper seating of components, i.e. no gaps, etc.
- U-bolt locknuts must be torqued to specification, refer to Torque Specification Section of this publication. **DO NOT** exceed specified torque on U-bolt locknuts.

FIGURE 6-1

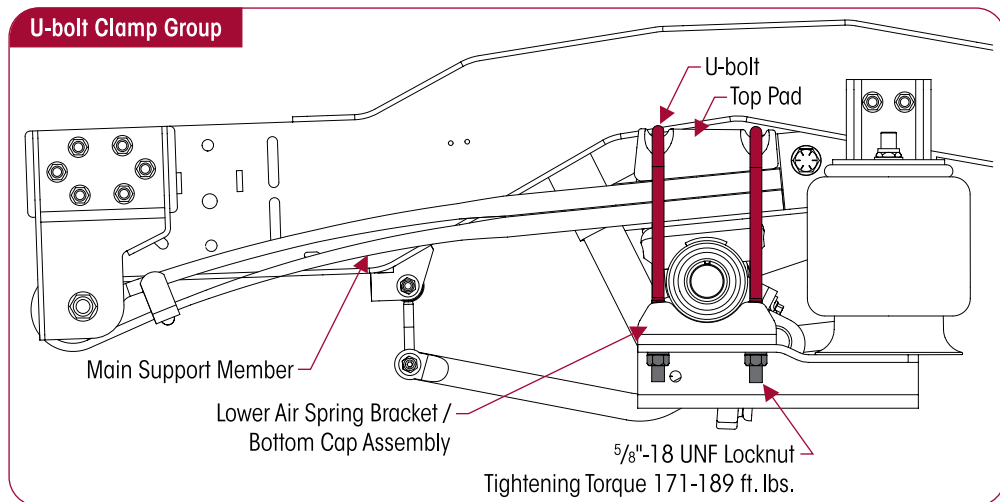

FIGURE 6-2

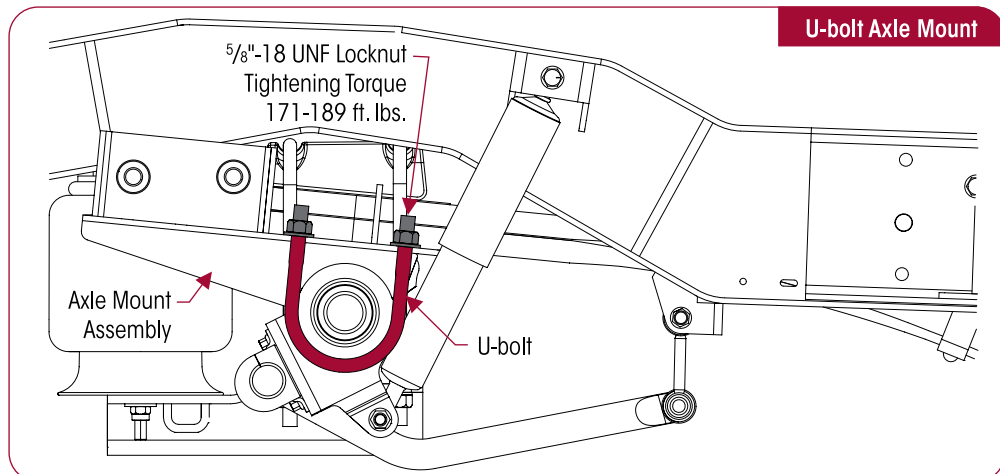
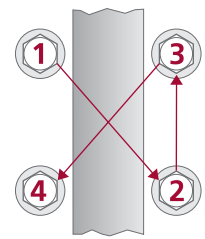



FIGURE 6-3



- U-bolt locknuts must be re-torqued at the following intervals:
  - At preparation for delivery.
  - At 1,000 miles of service on a new vehicle or vehicle with serviced axle attachment assembly.
  - Thereafter follow the six months / 20,000 miles, whichever comes first inspection and re-torque interval.
- Tighten U-bolt locknuts in the proper sequence, shown in Figure 6-3, evenly in 50 foot pounds increments to achieve uniform bolt tension of 171-189 foot pounds torque.

## TRANSVERSE TORQUE RODS

### WARNING

THE COMFORT AIR SUSPENSION INCORPORATES TRANSVERSE RODS FOR VEHICLE STABILITY. IF THESE COMPONENTS ARE DISCONNECTED OR ARE NON-FUNCTIONAL THE VEHICLE SHOULD NOT BE OPERATED. FAILURE TO DO SO CAN RESULT IN ADVERSE VEHICLE HANDLING, LOSS OF VEHICLE CONTROL, SEVERE PERSONAL INJURY, AND PREMATURE COMPONENT DAMAGE, AND POSSIBLE TIRE CONTACT WITH THE FRAME.

FIGURE 6-4

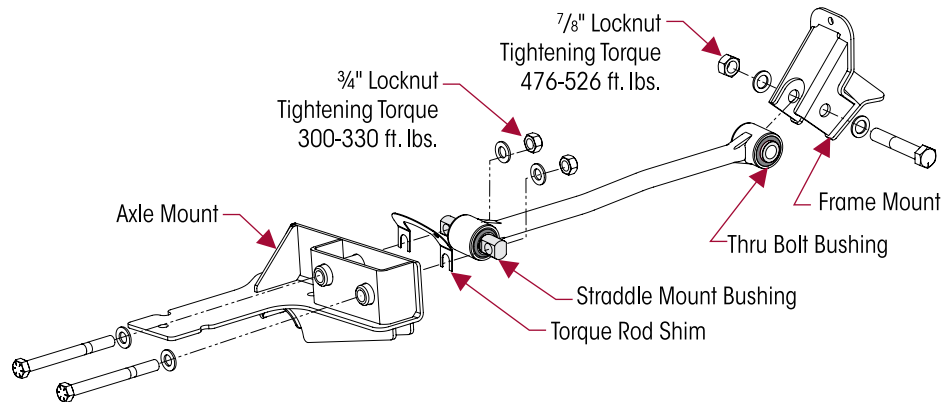

**Visually inspect torque rod bushings** for torn or shredded rubber, inspect for bent, cracked, or broken torque rods, and for end hubs with an elongated “oval” shape. Any of these conditions will require component replacement.

**Torque rod looseness** inspection is necessary. With the vehicle shut down, a lever check can be made with a long pry bar placed under each rod end and pressure applied.

**Torque rod length** is determined by the vehicle manufacturer to center the axles under the frame.

- If the lateral alignment of the axles is incorrect, it may be necessary to shim the transverse torque rod at the straddle mount end, see Figure 6-4. Refer to Lateral Alignment in the Alignment & Adjustments Section of this publication.
- The transverse torque rods also control axle walk-out during cornering. The mounting brackets at the axle housing end of the torque rods are furnished and welded into position on the axle housings by the axle or vehicle manufacturer.

The torque rod may be serviced by pressing out the worn bushings and installing new replacement bushings, see torque rod removal and bushing replacement in the Component Replacement Section of this publication.



## AIR FITTING INSPECTION

1. If an air leak is suspected, begin by building up the air system to normal operating pressure.
2. Spray all nylon tube air fittings with a soapy water solution to detect the leak location.

### NOTE

Air lines and fittings may be inspected for leaks using a soapy water solution.

3. If an air leak is located, ensure the tubing end is clean and in good condition and the end is cut square. Check to see if the tubing is binding, bent or being pulled upon.
4. Visually inspect the air fitting's O-ring seal for signs of damage or contamination.

## SHOCK ABSORBER

Hendrickson uses a long service life, premium shock absorber on all COMFORT AIR suspensions. If shock absorber replacement is necessary, Hendrickson recommends that the shock absorbers be replaced with original Hendrickson Genuine parts for servicing. Failure to do so will affect the suspension performance, durability, and will void the warranty.

Inspection of the shock absorber can be performed by doing a heat test, and a visual inspection, also inspect the shock absorber mounting brackets and hardware for damage or wear, replace as necessary. See instructions on shock absorber replacement in the Component Replacement Section of this publication. It is not necessary to replace shock absorbers in pairs if one shock absorber requires replacement.

### HEAT TEST

1. Drive the vehicle at moderate speeds on rough road for minimum of fifteen minutes.

### WARNING

DO NOT GRAB THE SHOCK AS IT COULD POSSIBLY CAUSE PERSONAL INJURY.

2. Use an infrared thermometer to check the temperature of the shock absorber. This can also be performed by carefully touching the shock body below the dust cover. Touch the frame to get an ambient reference, see Figure 6-5. A warm shock absorber is acceptable, a cold shock absorber should be replaced.
3. To inspect for an internal failure, remove and shake the suspected shock. Listen for the sound of metal parts rattling inside. Rattling of metal parts can indicate that the shock has an internal failure.

If the shock is damaged install new shock absorber as detailed in the Component Replacement Section of this publication.

FIGURE 6-5





### VISUAL INSPECTION

Look for these potential problems when doing a visual inspection, see Figure 6-6. Inspect the shock absorbers fully extended. Replace as necessary.

FIGURE 6-6

#### SHOCK ABSORBER VISUAL INSPECTION - UNACCEPTABLE CONDITIONS



### LEAKING VS. MISTING SHOCK VISUAL INSPECTION

The inspection must not be conducted after driving in wet weather or a vehicle wash. Shocks needs to be free from water. Many misting shocks are often misdiagnosed as leaks or failures. Misting is the process whereby very small amounts of shock fluid evaporate at a high operating temperature through the upper seal of the shock. When the "mist" reaches the cooler outside air, it condenses and forms a film on the outside of the shock body. Misting is perfectly normal and necessary function of the shock. The fluid which evaporates through the seal area helps to lubricate and prolong the life of the seal.

A shock that is leaking and needs to be replaced will show signs of fluid leaking in streams from the upper seal. These streams can easily be seen when the shock is fully extended, underneath the main body (dust cover) of the shock, see Figure 6-7. Look for these potential problems when doing a visual inspection. Inspect the shock absorbers fully extended. Replace as necessary.

FIGURE 6-7



**NOTE**

The COMFORT AIR suspension is equipped with a premium seal on the shock, however this seal will allow for misting to appear on the shock body (misting is not a leak and is considered acceptable).

## SECTION 7

## Alignment &amp; Adjustments

**LATERAL ALIGNMENT**

1. Use a work bay with a level surface.
2. Relax the suspension by slowly moving the vehicle back and forth several times in a straight line without using the brakes. This will slacken or loosen the suspension as the vehicle is positioned. End with all wheels positioned straight ahead.
3. **DO NOT** set the parking brake. Chock the front wheels of the vehicle.
4. Verify and maintain the air system at full operating pressure.
5. Verify the vehicle is at the correct ride height. Correct as necessary. Refer to Ride Height Adjustment in this section.
6. Verify all suspension components are in good condition. Repair or replace any worn or damaged suspension components before proceeding with the alignment process.
7. Ensure all drive axle tires are the same size and properly inflated.
8. Measure from the outside of the frame rail to the rim flange of the inner tire. Record the measurement.
9. Measure the same distance on the opposite side of the same axle. Record the measurement.
10. Subtract the two measurements to get a difference between the two. If the difference is greater than  $\frac{1}{8}$ " (3 mm), it will be necessary to correct the lateral alignment. Adding or removing shims as shown in Figure 7-1 accomplishes this.

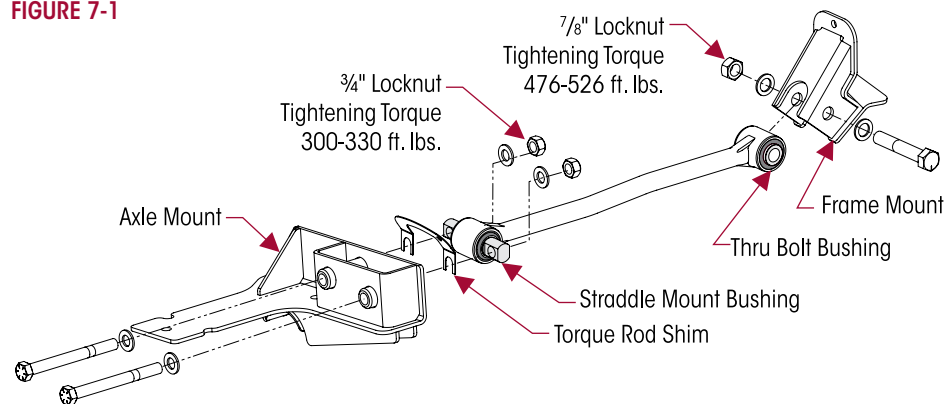
**FIGURE 7-1**

- A general rule of thumb is to use a torque rod shim with a thickness that is half of the difference between the two measurements.
- Torque rod shims can be installed between the transverse torque rod and the transverse left hand only torque rod axle mount assembly.

**EXAMPLE**

If the lateral alignment is out of specification by  $\frac{1}{4}$ " (6 mm), remove or install a  $\frac{1}{8}$ " (3 mm) shim between the transverse torque rod and left hand axle mount assembly as needed, see Figure 7-1. Refer to Transverse Torque Rod Section in Preventive Maintenance Section of this publication.

It is important to check the transverse torque rod fasteners for proper torque during preventive maintenance service intervals, refer to Torque Specifications Section of this publication.



## PINION ANGLE

The vehicle manufacturer establishes drive axle pinion angles. If it is necessary to fine-tune the pinion angle it will be necessary to contact the vehicle manufacturer.

### TO CHECK THE PINION ANGLE

1. Use a work bay with a level floor. Drive the vehicle slowly, straight ahead. Try to slacken or loosen the suspension as the vehicle is positioned. End with all wheels positioned straight ahead.
2. Verify vehicle is at the proper ride height, per the vehicle manufacturer's specifications.
3. Install a digital protractor on the drive axle housing as shown in Figure 7-2.
4. Verify the pinion angle is correct per the vehicle manufacturer's specifications. If an adjustment is needed please contact the vehicle manufacturer.

**FIGURE 7-2**



## DRIVE AXLE ALIGNMENT INSPECTION

Proper drive axle alignment is essential for maximum ride quality, performance, and tire service life. The recommended alignment procedure is described below. This procedure should be performed if excessive or irregular tire wear is observed, or any time the main support member is removed for service.

1. Use a work bay with a level surface.
2. Relax the suspension by slowly moving the vehicle back and forth several times in a straight line without using the brakes. This will slacken or loosen the suspension as the vehicle is positioned. End with all wheels positioned straight ahead.
3. **DO NOT** set the parking brake. Chock the front wheels of the vehicle.
4. Verify and maintain the air system is at full operating pressure.
5. Verify the vehicle is at the correct ride height. Correct as necessary. Refer to the vehicle manufacturer for proper ride height setting.
6. Verify all suspension components are in good condition. Repair or replace any worn or damaged suspension components before proceeding with the alignment process.
7. Ensure all drive axle tires are the same size and properly inflated.
8. If axle alignment equipment is not available, using "C" clamps, securely clamp a six-foot piece of straight bar stock or angle iron across the lower frame flange as shown in Figure 7-3. Select a location for the angle iron as far forward of the drive axle as possible where components will not interfere.
9. Accurately square the straight edge to the frame using a carpenter's square.
10. Using a measuring tape, measure from the straight edge to the forward face of the front drive axle arms at the axle centerline on both sides of the vehicle as shown in Figure 7-3, **A** and **B**.

**FIGURE 7-3**

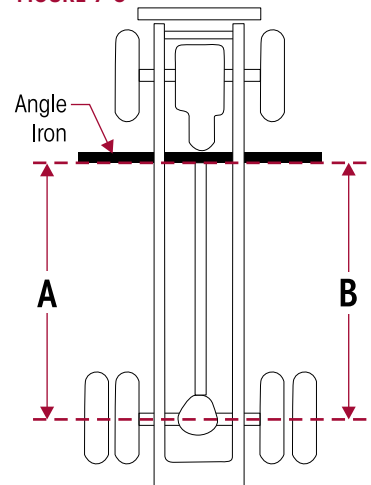



11. Calculate the difference between measurements **A** and **B**.
  - a. If the front drive axle is within vehicle manufacturer's specifications then the alignment of drive axle is acceptable.
  - b. If alignment of the front drive axle **IS NOT** within the vehicle manufacturer's specifications, then contact vehicle manufacturer. When all drive axle alignments and pinion angles are within the vehicle manufacturer's specifications then the alignment procedure is complete.

## SECTION 8

# Component Replacement

### FASTENERS

Hendrickson recommends, when servicing the vehicle, replace all removed fasteners with new equivalent fasteners. Maintain correct torque values at all times. Check torque values as specified. See Hendrickson's Torque Specifications Section in this publication for Hendrickson supplied fasteners. If non-Hendrickson fasteners are used, follow torque specifications listed in the vehicle manufacturer's service manual.

### HEIGHT CONTROL VALVE

The height control valve is not supplied by Hendrickson, although it is a required component. Hendrickson is not responsible for components supplied by the vehicle manufacturer. For assistance with inspection, maintenance and rebuild instructions on these components see vehicle manufacturer.

### AIR SPRING

#### DISASSEMBLY

1. Chock the front wheels.
2. Raise and support the frame at the rear of the vehicle at ride height.

**WARNING**

THE VEHICLE MUST BE FIRMLY SUPPORTED WITH JACK STANDS PRIOR TO SERVICING. FAILURE TO DO SO CAN RESULT IN PERSONAL INJURY OR PROPERTY DAMAGE.

3. Disconnect the height control linkage assembly from the height control valve arm per the vehicle manufacturer's instructions.

**WARNING**

PRIOR TO AND DURING DEFLATION AND INFLATION OF THE AIR SUSPENSION SYSTEM, ENSURE THAT ALL PERSONNEL AND EQUIPMENT ARE CLEAR FROM UNDER THE VEHICLE AND AROUND THE SERVICE AREA, FAILURE TO DO SO CAN CAUSE SERIOUS PERSONAL INJURY, DEATH, OR PROPERTY DAMAGE.

4. See additional Air Spring Cautions and Warnings in the Important Safety Notice Section of this publication prior to deflating or inflating the air system.

5. Lower the height control valve arm to exhaust the air in the air springs and deflate the rear suspension.
6. Remove the air line from the air spring.
7. Remove air fittings from air spring.
8. Remove the lower air spring fasteners that connect air spring to the lower air spring bracket / bottom cap assembly, see Figure 8-1.
9. Remove the 3/4" fasteners that connect air spring to the upper air spring bracket, see Figure 8-1.
10. Remove the air spring.

**FIGURE 8-1**

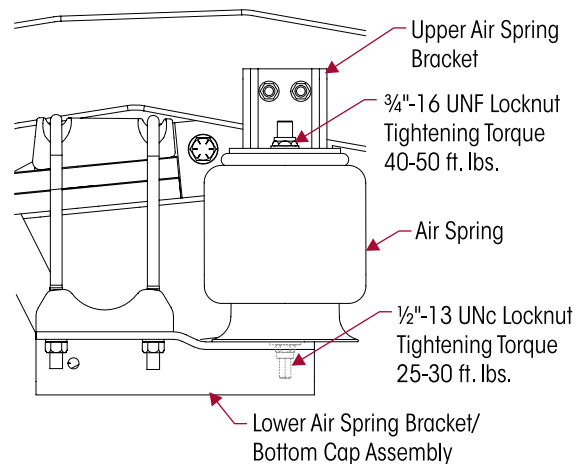

### INSPECTION

1. Inspect the mounting surfaces and lower air spring bracket / bottom cap assembly for any damage. Replace as necessary.
2. Inspect upper air spring bracket for cracks. Replace as necessary.

### ASSEMBLY

1. Install the air spring between the upper and lower air spring bracket / bottom cap assembly, see Figure 8-2.

### CAUTION

FAILURE TO PRESS THE AIR SPRING AGAINST THE UNDERSIDE OF THE UPPER AIR SPRING BRACKET WHILE TIGHTENING THE UPPER AIR SPRING BRACKET CAN RESULT IN COMPONENT DAMAGE AND PERSONAL INJURY OR PROPERTY DAMAGE.

2. Install the air spring lower mounting stud through the lower air spring bracket / bottom cap assembly hole. Attach the 1/2" fasteners to the lower mounting stud of the air spring. **USING HAND TOOLS ONLY**, tighten the locknut to 25-30 foot pounds torque, see Figure 8-2.
3. Install the air spring to upper air spring bracket. Tighten the locknut to 40-50 foot pounds torque, see Figure 8-2.
4. Re-install the air fittings.
5. Connect the air line to the air spring.
6. See additional Air Spring Cautions and Warnings in the Important Safety Notice Section of this publication prior to deflating or inflating the air system.
7. Inflate the suspension by connecting the height control valve linkage to the height control valve arm per the vehicle manufacturer's instructions. Verify the air springs inflate uniformly without binding.
8. Remove the frame supports.
9. Remove the wheel chocks.
10. Verify the vehicle's ride height is within specifications per the vehicle manufacturer.

FIGURE 8-2

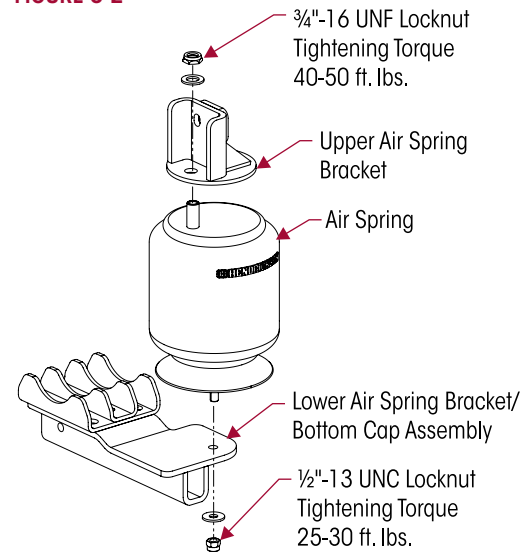

## SHOCK ABSORBER

### DISASSEMBLY

1. Chock the wheels of the vehicle.
2. Remove the 1/2" fastener, that connect shock absorber to frame hanger and to lower shock bracket, see Figure 8-3.
3. Slide the shock absorber out of the lower mounting bracket.
4. Remove the shock absorber from the upper mounting stud.
5. Inspect the shock absorber mounting brackets and hardware for damage or wear, and replace as necessary, see the Preventive Maintenance Section of this publication.

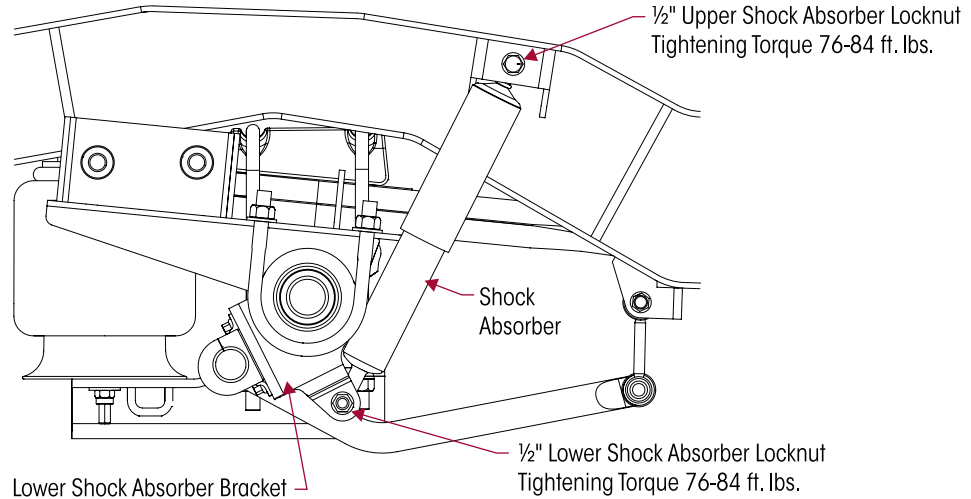
**FIGURE 8-3**

**ASSEMBLY**

1. Install shock absorber to frame bracket stud by attaching 1/2" bolt, washers and locknut.
2. Install shock absorber to lower shock bracket by attaching the 1/2" bolt, washers, and locknut.
3. Tighten 1/2" locknut to 76-84 foot pounds torque, see Figure 8-3.
4. Remove the wheel chocks.
5. Verify the vehicle's ride height is within the vehicle manufacturer's specifications.

**SHOCK ABSORBER LOWER MOUNTING BRACKET**
**NOTE**

The shock absorber lower mounting bracket is not supplied by Hendrickson, although it is a required component. Hendrickson is not responsible for components supplied by the vehicle manufacturer. For assistance with inspection, maintenance and rebuild instructions on these components see vehicle manufacturer.

**TRANSVERSE TORQUE ROD**
**WARNING**

THE COMFORT AIR SUSPENSION INCORPORATES TRANSVERSE RODS FOR VEHICLE STABILITY. IF THESE COMPONENTS ARE DISCONNECTED OR ARE NON-FUNCTIONAL THE VEHICLE SHOULD NOT BE OPERATED. FAILURE TO DO SO CAN RESULT IN ADVERSE VEHICLE HANDLING, LOSS OF VEHICLE CONTROL, SEVERE PERSONAL INJURY, AND PREMATURE COMPONENT DAMAGE, AND POSSIBLE TIRE CONTACT WITH THE FRAME.

**DISASSEMBLY**

1. Chock the front wheels of the vehicle.
2. Support the frame at the rear of the vehicle at ride height.

**WARNING**

THE VEHICLE MUST BE FIRMLY SUPPORTED WITH JACK STANDS PRIOR TO SERVICING. FAILURE TO DO SO CAN RESULT IN PERSONAL INJURY OR PROPERTY DAMAGE.

**SERVICE HINT**

Note the quantity and location of torque rod shims removed during disassembly. The same quantity **MUST** be reinstalled in the same location in order to maintain the lateral alignment of the axle prior to disassembly. The lateral alignment procedure will need to be performed after assembly, see Alignment & Adjustments Section of this publication.

3. Remove and discard the transverse torque rod fasteners.
4. Remove the transverse torque rod and torque rod shims.

### INSPECTION

1. Inspect the torque rod mating surfaces for any wear or damage. Repair or replace as necessary.
2. Inspect the rubber bushings for wear or damage, replace as necessary.
3. Inspect the torque rod for wear, or cracks, replace as necessary.
4. Inspect the transverse torque rod axle mount and frame mount for wear or damage, repair as necessary.

**FIGURE 8-4**

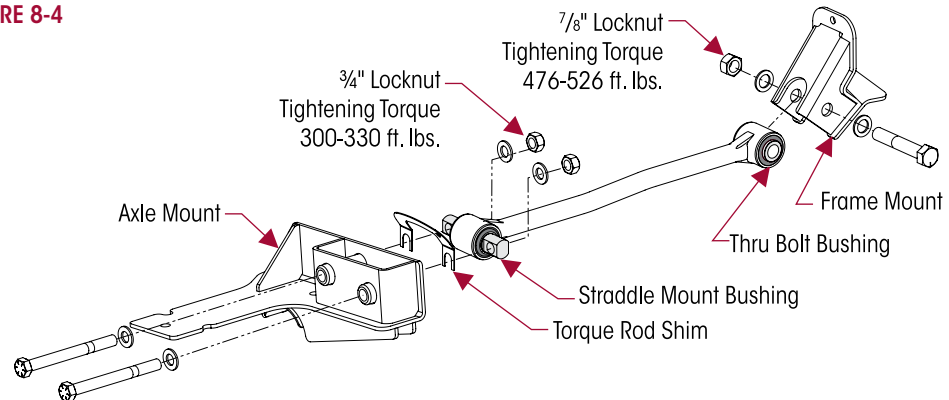

### ASSEMBLY

1. Install the transverse torque rod by attaching  $\frac{3}{4}$ " fasteners to the axle mount and tighten to 300-330 foot pounds torque, see Figure 8-4.
1. Install the transverse torque rod by attaching  $\frac{7}{8}$ " fasteners to the frame mount and tighten to 476-526 foot pounds torque, see Figure 8-4.
2. Verify lateral axle alignment, and correct by adding or removing torque rod shims between the torque rod bar pin and axle mount, depending on the direction of alignment.
3. Remove jack stands.
4. Remove wheel chocks.

### TORQUE ROD BUSHING

#### DISASSEMBLY

You will need:

- A vertical press with a capacity of at least 10 tons
- Shop made tools: receiving tool, installation/removal tool (see Special Tools in this publication for specifications)
- Funnel Tool 66086-001L see the Special Tools Section of this publication

### CAUTION

DO NOT USE HEAT OR USE A CUTTING TORCH TO REMOVE THE BUSHINGS FROM THE TORQUE ROD. THE USE OF HEAT WILL ADVERSELY AFFECT THE STRENGTH OF THE TORQUE ROD; HEAT CAN CHANGE THE MATERIAL PROPERTIES. A COMPONENT DAMAGED IN THIS MANNER CAN RESULT IN THE LOSS OF VEHICLE CONTROL, POSSIBLE PERSONAL INJURY OR PROPERTY DAMAGE AND VOID WARRANTY.

1. Remove the transverse torque rod as detailed in this section.

### SERVICE HINT

When servicing a straddle mount bar pin type bushing assembly, mark the clocking position of the straddle mount bar pin flats on the torque rod end hub before disassembly. This clocking mark will serve as a guide when installing the new bushing assembly so the original clocking position can be retained.

- When replacing a straddle mount bar pin type bushing assembly, mark the clocking position of the bushing assembly's bar pin flats with a paint stick on the torque rod end hub prior to disassembly, see Figure 8-5.

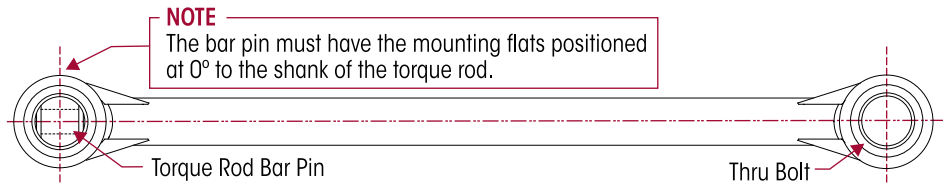
**FIGURE 8-5**

- Install the torque rod in the press. Support the torque rod end on the receiving tool with the end of the torque rod centered on the tool. Be sure the torque rod is squarely supported on the press bed.
- Push directly on the inner metal of the bushing assembly until the bushing assembly clears the torque rod end tube.
- Clean and inspect the inner diameter of the torque rod ends.

### ASSEMBLY

**NOTE**

**DO NOT** use a petroleum or soap base lubricant. Such lubricants can cause adverse reactions with the bushing, such as deterioration of the rubber, causing premature failure.

- Lubricate the inner diameter of the torque rod end hub and the new rubber bushing with P-80 Lubricant (refer to the Parts List Section of this publication) or light Naphthenic Base Oil, such as 60 SUS at 100°F, see Figure 8-6.
- Support the torque rod end hub on the receiving tool with the end hub of the torque rod centered on the receiving tool.

**SERVICE HINT**

When replacing a straddle mount bar pin type bushing assembly, verify the correct clocking position of the straddle mount bar pin flats prior to installing the bushing assembly in the torque rod end hub.

- Verify the bar pin flats are clocked correctly.
- Press directly on the inner metal of the bushing assembly.
- When pressing in the new bushings overshoot the desired final position by approximately  $\frac{3}{16}$ ", see Figure 8-7.
- Press the inner metal of the bushing assembly again from opposite side to center the bushing and inner metal within the torque rod end hub, see Figure 8-8.
- Wipe off excess lubricant. Allow the lubricant four (4) hours to dissipate before operating vehicle.

**FIGURE 8-6**

**FIGURE 8-7**

**FIGURE 8-8**

**CAUTION**

IF THE TORQUE ROD ASSEMBLY IS NOT ALLOWED SUFFICIENT TIME FOR THE LUBRICANT TO DISSIPATE, THE BUSHING MAY SLIDE FROM THE TORQUE ROD END TUBE. THE BUSHING WILL THEN NEED TO BE REMOVED AND A NEW BUSHING RE-INSTALLED.

8. Install the torque rod assembly as detailed in this section.

**CLAMP GROUP – TOP PAD & LOWER AIR SPRING BRACKET/  
BOTTOM CAP ASSEMBLY****WARNING**

THE PROCEDURE TO DISASSEMBLE THE CLAMP GROUP IS DONE WITH THE OTHER MAIN SUPPORT MEMBER PROPERLY CONNECTED TO THE FRAME HANGER AND AXLE. FAILURE TO HAVE THE OTHER MAIN SUPPORT MEMBER CONNECTED PROPERLY COULD ALLOW THE AXLE TO SHIFT RESULTING IN POSSIBLE DAMAGE TO COMPONENTS AND/OR PERSONAL INJURY. IF THE OTHER MAIN SUPPORT MEMBER IS NOT PROPERLY CONNECTED TO THE FRAME HANGER AND AXLE IT WILL BE NECESSARY TO SUPPORT THE AXLE PINION TO KEEP THE AXLE FROM SHIFTING.

**DISASSEMBLY**

1. Chock the front wheels.
2. Support the frame at the rear of the vehicle at ride height.

**WARNING**

THE VEHICLE MUST BE FIRMLY SUPPORTED WITH JACK STANDS PRIOR TO SERVICING. FAILURE TO DO SO CAN RESULT IN PERSONAL INJURY OR PROPERTY DAMAGE.

3. Disconnect the height control linkage assembly from the height control valve per the vehicle manufacturer's specifications.

**WARNING**

PRIOR TO AND DURING DEFLATION AND INFLATION OF THE AIR SUSPENSION SYSTEM, ENSURE THAT ALL PERSONNEL AND EQUIPMENT ARE CLEAR FROM UNDER THE VEHICLE AND AROUND THE SERVICE AREA, FAILURE TO DO SO CAN CAUSE SERIOUS PERSONAL INJURY, DEATH, OR PROPERTY DAMAGE.

4. See additional Air Spring Cautions and Warnings in the Important Safety Notice Section of this publication prior to deflating or inflating the air system.
5. Lower the height control valve arm to exhaust the air in the air springs and deflate the rear suspension.
6. On the side being serviced, remove and discard the clamp group U-bolt fasteners, see Figure 8-9.
7. Remove the lower air spring bracket / bottom cap assembly and top pad.

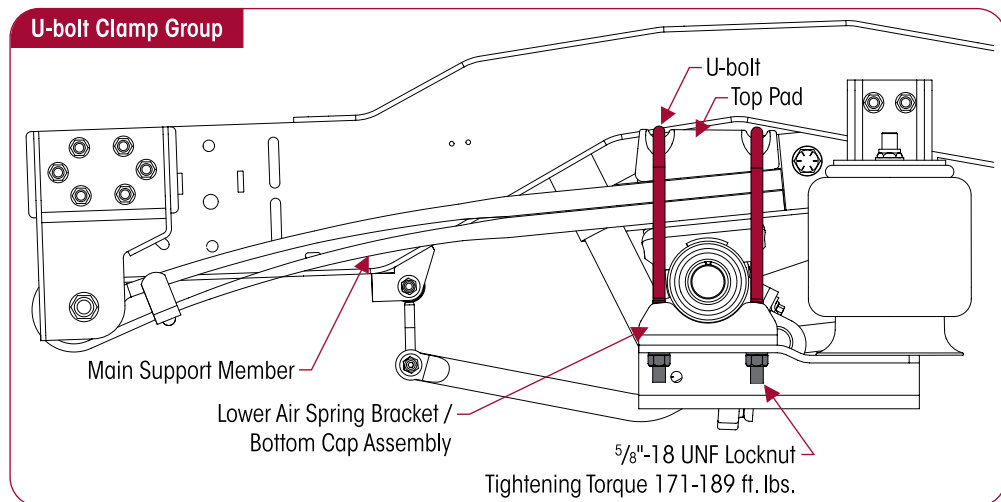
**FIGURE 8-9**





## INSPECTION

### WARNING

FAILURE OF THE MAIN SUPPORT MEMBER BETWEEN THE U-BOLTS WILL REQUIRE THE REPLACEMENT OF THE MAIN SUPPORT MEMBER AND ALL CLAMP GROUP COMPONENTS. FAILURE TO DO SO CAN RESULT IN CLAMP GROUP FAILURE AND FURTHER FAILURE TO THE MAIN SUPPORT MEMBER, WHICH CAN CAUSE LOSS OF VEHICLE CONTROL, PROPERTY DAMAGE OR SEVERE PERSONAL INJURY.

1. Inspect the main support member for damage. Replace as necessary.
2. Inspect the lower air spring/bottom cap assembly for excessive wear and cracks or fretting. Replace as necessary.
3. Place a floor jack under the main support member being serviced.
4. Raise the main support member and inspect spring seat for wear and damage, note the spring seat is welded to the axle, see Figure 8-10. Refer to the vehicle manufacturer for replacement instructions.
5. Inspect the axle housing for any cracks or wear. Repair or replace as necessary.

**FIGURE 8-10**

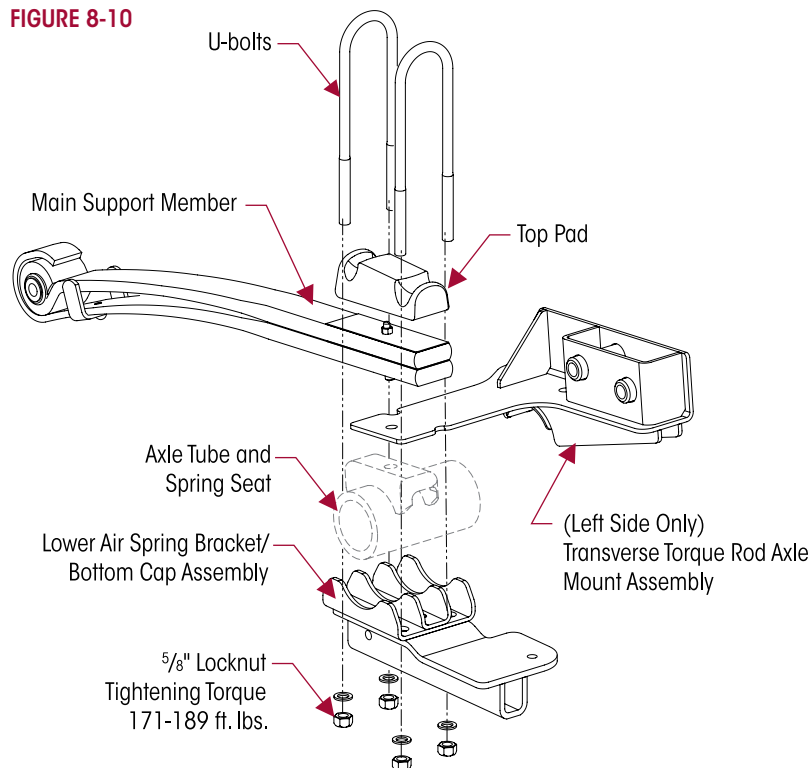

## ASSEMBLY

1. If replacement is on the left hand side, install the transverse torque rod axle mount assembly on the spring seat.
2. Lower the main support member on the spring seat.
3. Ensure the locator pin on the bottom of the main support member engages the (left hand transverse torque rod axle mount assembly if equipped) spring seat locator hole.
4. Install the top pad on the top of the main support member. Ensure the locator hole on the bottom of the top pad engages the main support member locator pin.

### WARNING

U-BOLTS THAT ARE FOUND TO BE LOOSE REQUIRE THAT MATING COMPONENTS BE INSPECTED FOR SIGNS OF WEAR OR FRETTING. ANY COMPONENTS WORN MUST BE REPLACED. FAILURE TO DO SO CAN CAUSE PREMATURE CLAMP GROUP FAILURE, COMPONENT DAMAGE, LOSS OF VEHICLE CONTROL, PROPERTY DAMAGE, OR SEVERE PERSONAL INJURY. MAINTAIN CORRECT TORQUE VALUE AT ALL TIMES. CHECK TORQUE VALUES ON A REGULAR BASIS AS SPECIFIED.

5. Install **NEW** U-bolts, flat washers and locknuts.

**WARNING**

- Verify that the top pad and lower air spring/bottom cap assembly are installed correctly.

IT IS IMPORTANT THAT THE U-BOLT CLAMP GROUP CONNECTION BE PROPERLY ALIGNED AND HAVE THE PROPER TIGHTENING TORQUE VALUES MAINTAINED. METAL SURFACES CAN WORK AND WEAR AGAINST OTHER RELATED CLAMP GROUP COMPONENTS IF NOT PROPERLY ALIGNED OR PROPERLY TIGHTENED TO MAINTAIN THE PROPER CLAMP FORCE. FAILURE TO DO SO CAN CAUSE PREMATURE COMPONENT WEAR, POSSIBLE SEPARATION OF THE CLAMP GROUP, CAUSING LOSS OF VEHICLE CONTROL, PROPERTY DAMAGE, OR PERSONAL INJURY.

- Verify that the U-bolts are seated properly in the channels of the top pad, see Figure 8-10.
- Verify the secondary leaf and main support member are centered in the frame hanger.

FIGURE 8-11

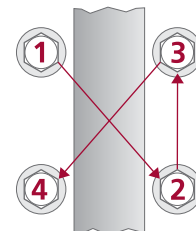

- Snug U-bolts prior to tightening, applying a crisscross pattern, (approximately  $\mathbb{N}$  100 foot pounds tightening torque), see Figure 8-11.
- Tighten the U-bolt locknuts evenly to  $\mathbb{N}$  171-189 foot pounds torque, see Figure 8-10.
- Rap the top of the U-bolts with a dead blow mallet, and retighten to specified torque. **DO NOT** exceed specified torque on U-bolt locknuts.
- See additional Air Spring Cautions and Warnings in the Important Safety Notice Section of this publication prior to deflating or inflating the air system.
- Inflate the suspension by connecting the height control valve linkage to the height control valve arm per the vehicle manufacturer's instructions. Verify the air springs inflate uniformly without binding.
- Remove the frame supports.
- Remove the wheel chocks.
- Verify the vehicle's ride height is within specifications per the vehicle manufacturer.

**MAIN SUPPORT MEMBER**

The main support member should function satisfactorily during normal vehicle operation. Replacement is only required when the main support member is damaged or worn.

**CAUTION**

THIS PROCEDURE TO REPLACE A MAIN SUPPORT MEMBER IS DONE WITH THE OTHER MAIN SUPPORT MEMBER PROPERLY CONNECTED TO THE FRAME HANGER AND AXLE. FAILURE TO HAVE THE OTHER MAIN SUPPORT MEMBER CONNECTED PROPERLY COULD ALLOW THE AXLE TO SHIFT RESULTING IN POSSIBLE DAMAGE TO COMPONENTS AND/OR PERSONAL INJURY. IF BOTH MAIN SUPPORT MEMBERS ARE TO BE REMOVED IT WILL BE NECESSARY TO SUPPORT THE AXLE PINION TO KEEP THE AXLE FROM SHIFTING.

**DISASSEMBLY**

- Chock the front wheels.
- Support the frame at the rear of the vehicle at ride height.

**WARNING**

THE VEHICLE MUST BE FIRMLY SUPPORTED WITH JACK STANDS PRIOR TO SERVICING. FAILURE TO DO SO CAN RESULT IN PERSONAL INJURY OR PROPERTY DAMAGE.

- Disconnect the height control linkage assembly from the height control valve arm per the vehicle manufacturer's instructions.
- Remove the air spring(s) per the Air Spring Disassembly instructions in this section.
- On the side being serviced, remove and discard the U-bolts locknuts and washers.
- Remove the lower air spring bracket / bottom cap assembly and top pad. If servicing the right hand side, also remove the axle spacer.
- Support the main support member by placing a hydraulic jack under the spring eye bushing.



8. Remove the spring eye fasteners, see Figure 8-12.
9. Slide the spring eye bushing down and out of the frame hanger. Remove the main support assembly.

## INSPECTION

### WARNING

U-BOLTS THAT ARE FOUND TO BE LOOSE REQUIRE THAT MATING COMPONENTS BE INSPECTED FOR SIGNS OF WEAR OR FRETTING. ANY COMPONENTS WORN MUST BE REPLACED. FAILURE TO DO SO CAN CAUSE PREMATURE CLAMP GROUP FAILURE, COMPONENT DAMAGE, LOSS OF VEHICLE CONTROL, PROPERTY DAMAGE, OR SEVERE PERSONAL INJURY. MAINTAIN CORRECT TORQUE VALUE AT ALL TIMES. CHECK TORQUE VALUES ON A REGULAR BASIS AS SPECIFIED.

1. Inspect the frame hanger for excessive wear, cracks and proper frame hanger fastener torque. Replace as necessary.
2. Inspect the main support member for damage. Replace as necessary.
3. Inspect the top pad, axle tube and lower air spring bracket / bottom cap assembly for excessive wear and cracks or fretting. Replace as necessary.
4. Inspect spring seat excessive wear, cracks or fretting (it may be necessary to remove the transverse torque rod axle mount assembly from the left hand side or the axle spacer from the right hand side to inspect the spring seat).
5. Inspect the axle housing for any cracks or wear. Repair or replace as necessary.
6. Inspect the air spring for damage and inspect the lower piston and the upper air spring mount for cracks. Replace as necessary.

FIGURE 8-12

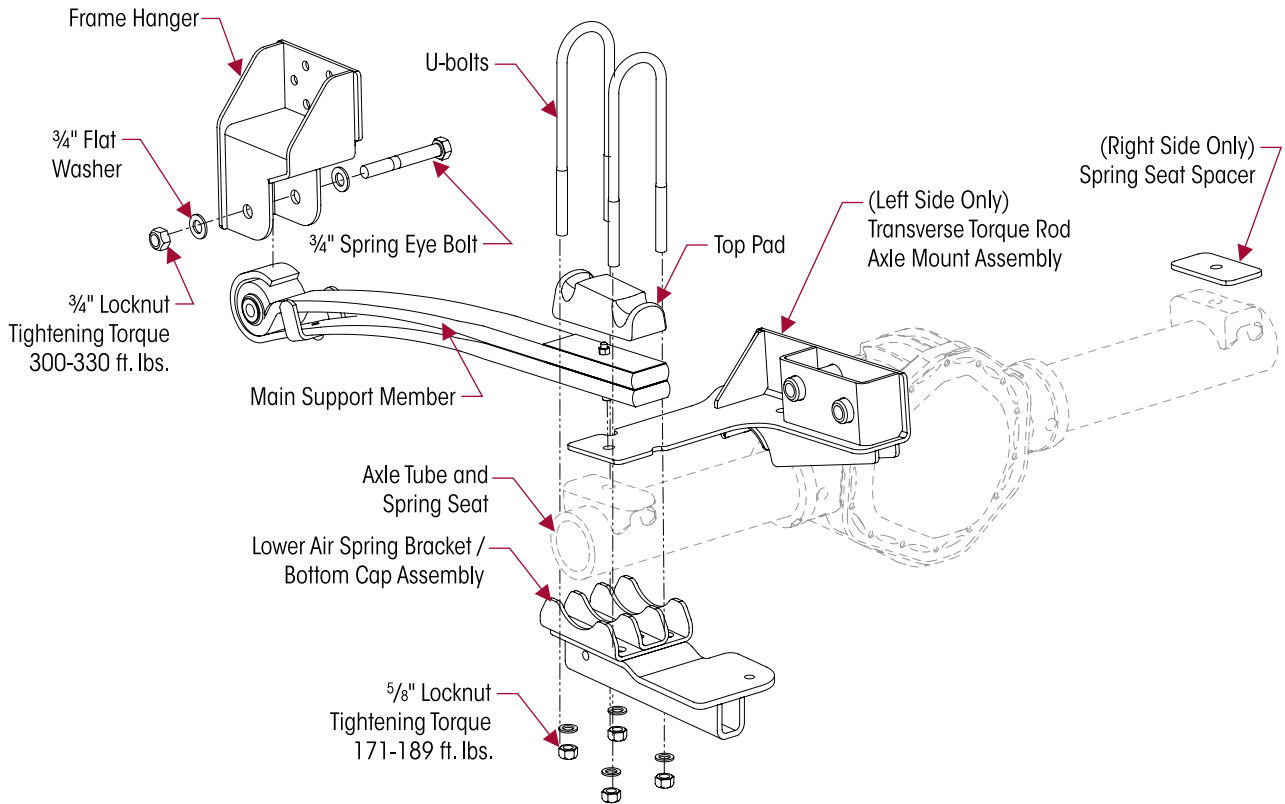



## WARNING

### ASSEMBLY

DO NOT STRIKE SUSPENSION COMPONENTS WITH A HAMMER. DO NOT NICK OR GOUGE THE MAIN SUPPORT MEMBER. SUCH IMPROPER ACTIONS CAN CAUSE DAMAGE; THE MAIN SUPPORT MEMBER COULD FAIL, AND CAUSE LOSS OF VEHICLE CONTROL AND POSSIBLE PERSONAL INJURY OR PROPERTY DAMAGE.

1. If servicing the left hand side, position the main support member on the transverse torque rod axle mount assembly.
2. Galvanized steel liner must be positioned on the topside of the main support member.
3. Align the bushing of the main support member under the opening of the frame hanger and jack into place.
4. Install the (install spacer if servicing the right hand side), top pad, lower air spring bracket / bottom cap assembly, (torque rod axle mount assembly if doing the left side), U-bolts and fasteners, see Figure 8-12.
5. Ensure all locators are engaged and clamp group is properly aligned.
6. Verify that the U-bolts are seated properly in the channels of the top pad, see Figure 8-12.

FIGURE 8-13

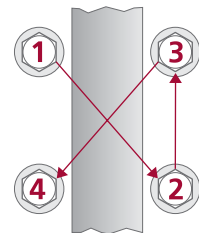

7. Snug U-bolts in a crisscross pattern, approximately 100 foot pounds tightening torque, see Figure 8-13.
8. Tighten the U-bolt locknuts evenly to 171-189 foot pounds torque, see Figure 8-12.
9. Rap the top of the U-bolts with a dead blow mallet, and retighten to specified torque. **DO NOT** exceed specified torque on U-bolt locknuts.
10. Install the air spring lower mounting stud through the lower air spring bracket / bottom cap assembly hole.
11. Attach the fasteners to the lower mounting stud of the air spring. **USING HAND TOOLS ONLY**, tighten the locknut to 20-30 foot pounds torque.
12. See additional Air Spring Cautions and Warnings in the Important Safety Notice Section of this publication prior to deflating or inflating the air system.
13. Inflate the suspension by connecting the height control valve linkage to the height control valve arm per the vehicle manufacturer's instructions. Verify the air springs inflate uniformly without binding.
14. Remove the frame supports.
15. Remove the wheel chocks.
16. Verify the vehicle's ride height is within specifications per the vehicle manufacturer.

### FRAME HANGER

The frame hanger should function satisfactorily during normal vehicle operation. Replacement is required when the frame hanger has been damaged or worn.

### DISASSEMBLY

1. Chock the front wheels.
2. Raise and support the frame at the rear of the vehicle at ride height.

## WARNING

THE VEHICLE MUST BE FIRMLY SUPPORTED WITH JACK STANDS PRIOR TO SERVICING. FAILURE TO DO SO CAN RESULT IN PERSONAL INJURY OR PROPERTY DAMAGE.

3. Disconnect the height control valve's linkage assembly from the height control valve arm per the vehicle manufacturer's instructions.



## WARNING

PRIOR TO AND DURING DEFLATION AND INFLATION OF THE AIR SUSPENSION SYSTEM, ENSURE THAT ALL PERSONNEL AND EQUIPMENT ARE CLEAR FROM UNDER THE VEHICLE AND AROUND THE SERVICE AREA, FAILURE TO DO SO CAN CAUSE SERIOUS PERSONAL INJURY, DEATH, OR PROPERTY DAMAGE.

4. See additional Air Spring Cautions and Warnings in the Important Safety Notice Section of this publication prior to deflating or inflating the air system.
5. Lower the height control valve arm to exhaust the air in the air springs and deflate the rear suspension.
6. Remove the  $\frac{3}{4}$ " fasteners that connect the main support member to the frame hanger, see Figure 8-14.
7. Remove the  $\frac{1}{2}$ " fasteners that attach the frame hanger to the vehicle frame.
8. Remove the frame hanger.

**FIGURE 8-14**

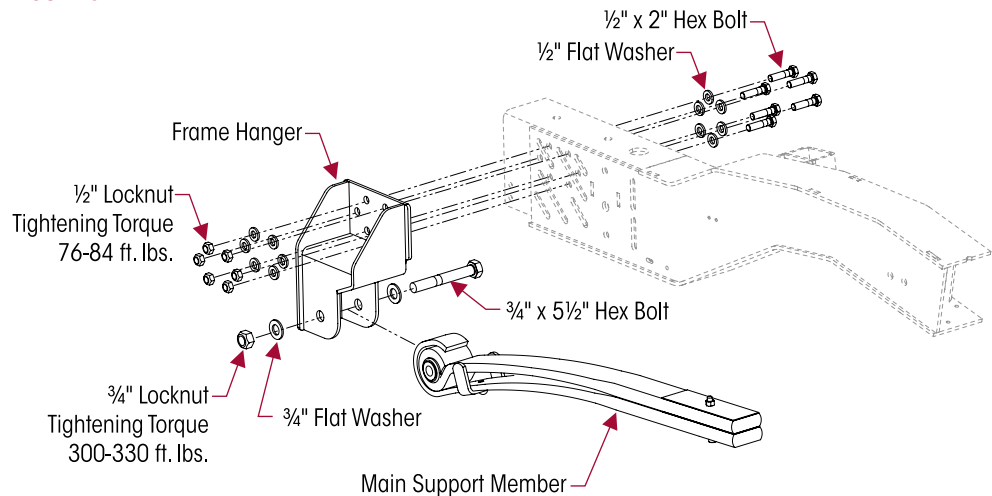

## INSPECTION

1. Inspect mounting surface of hanger and frame for any damage or wear. Repair or replace as necessary.
2. Inspect the main support member and bushing for wear or damage. Replace as necessary.

## ASSEMBLY

1. Slide the frame hanger over the main support member's bushing.
2. Install the new frame hanger fasteners and tighten to  76-84 foot pounds torque, see Figure 8-14.

## NOTE

Prior to tightening the spring eye bolt to final torque specifications, it is mandatory that the vehicle be positioned at the proper ride height.

3. See additional Air Spring Cautions and Warnings in the Important Safety Notice Section of this publication prior to deflating or inflating the air system.
4. Inflate the suspension by connecting the height control valve linkage to the height control valve arm per the vehicle manufacturer's instructions. Verify the air springs inflate uniformly without binding.
5. Remove the frame supports.
6. Verify the vehicle's ride height is within specifications per the vehicle manufacturer.
7. After the ride height verified tighten the spring eye fasteners to  300-330 foot pounds torque, see Figure 8-14.
8. Remove the wheel chocks.

# SECTION 9 Torque Specifications

## COMFORT AIR 10K

Hendrickson recommended torque values  
provided in Foot Pounds

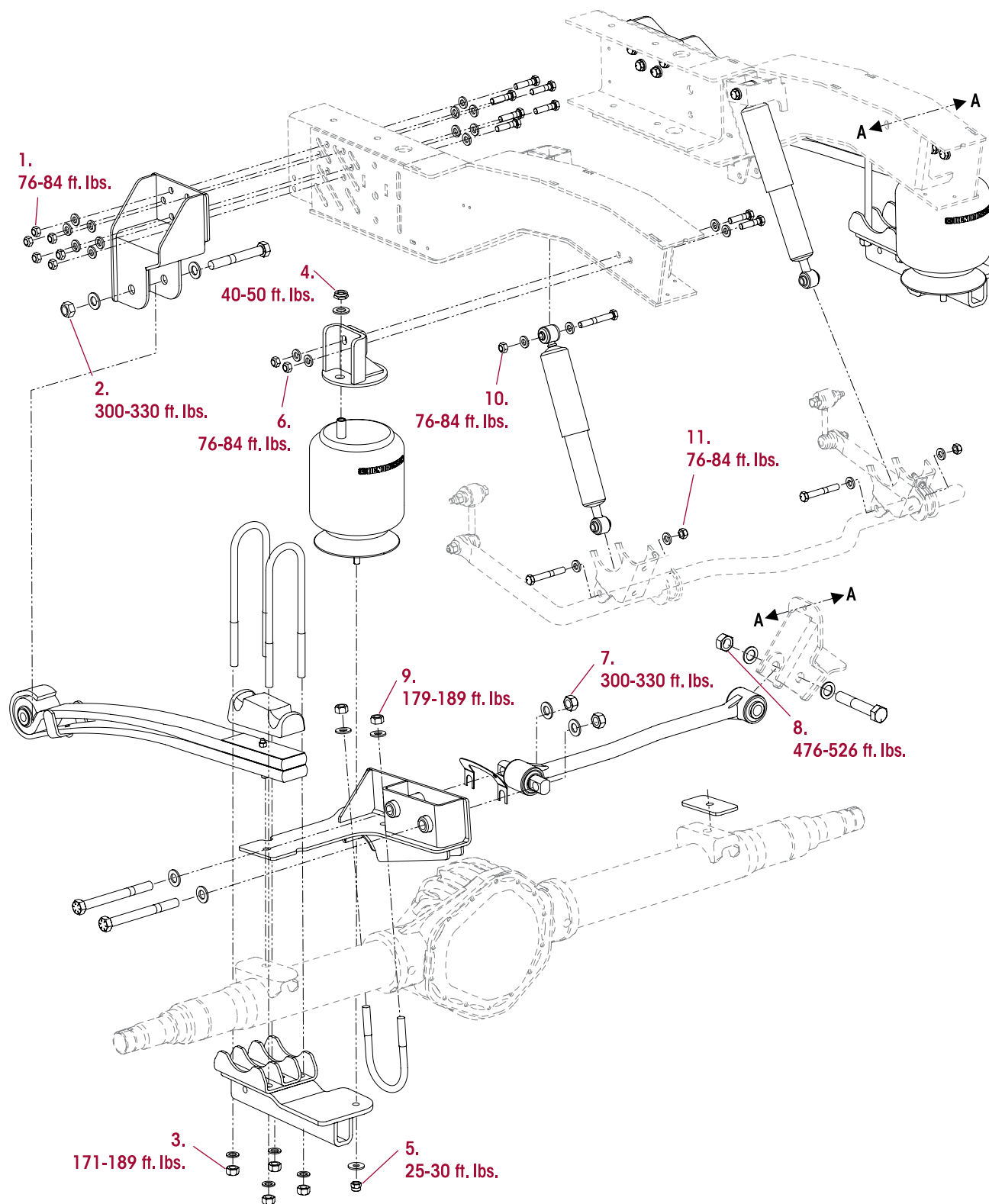



## COMFORT AIR 10K for ARBOC Specialty Vehicles

## HENDRICKSON RECOMMENDED TORQUE SPECIFICATIONS

NO.	COMPONENT	FASTENER		*TORQUE VALUE
		QUANTITY	SIZE	FOOT POUNDS
1.	Frame Hanger to Frame	12	½"-13 UNC	76-84
2.	Frame Hanger to Main Support Member	2	¾"-16 UNF	300-330
3.	U-bolts to Lower Air Spring Bracket / Bottom Cap Assembly	8	⅝"-18 UNF	171-189
4.	Air Spring to Upper Air Spring Bracket	2	¾"-16 UNF	40-50
5.	Air Spring to Lower Air Spring Bracket / Bottom Cap Assembly	2	½"-13 UNC	25-30
6.	Upper Air Spring Bracket to Frame	2	½"-13 UNC	76-84
7.	Torque Rod to Left Hand Transverse Rod Axle Mount	2	¾"-10 UNC	300-330
8.	Torque Rod to Frame Mount	1	⅞"-14 UNF	476-526
9.	U-bolt Hex Nut to Axle Mount	2	⅝"-18 UNF	171-189
10.	Upper Shock Absorber	2	½"-13 UNC	76-84
11.	Lower Shock Absorber	2	½"-13 UNC	76-84

**NOTE:** \* Torque values listed above apply only if Hendrickson supplied fasteners are used. If non Hendrickson fasteners are used, follow torque specification listed in vehicle manufacturer's service manual.



## SECTION 10

# Troubleshooting Guide

COMFORT AIR 10K TROUBLESHOOTING GUIDE		
CONDITION	POSSIBLE CAUSE	CORRECTION
Vehicle bouncing excessively	Leaking shock absorber	Replace shock absorber.
	Damaged shock absorber	Replace shock absorber.
	Air spring(s) not inflated	Check air supply to air spring, repair as necessary.
	Incorrect ride height	Adjust ride height to proper setting, refer to vehicle manufacturer's specifications.
Suspension has harsh or bumpy ride	Broken main support member	Replace the main support member.
	Damaged height control valve	Replace height control valve, per vehicle manufacturer's specifications.
	Incorrect ride height	Adjust ride height to proper setting, refer to vehicle manufacturer's specifications.
Excessive driveline vibration	Incorrect ride height	Adjust ride height to proper setting, refer to vehicle manufacturer's specifications.
	Broken main support member	Replace main support member.
	Air spring(s) not inflated	Check air supply to air spring, repair as necessary.
Vehicle leans	Broken main support member	Replace main support member.
	Axle connection not torqued correctly	Perform U-bolt re-torque procedure. See Torque Specification Section of this publication.
	Worn spring eye bushing	Replace main support member.
	Air spring(s) not inflated	Check air supply to air spring, repair as necessary.
Suspension is noisy	Loose spring eye connection	Check frame hanger and fasteners for wear and replace as necessary.
	Loose U-bolts	Perform U-bolt re-torque procedure. See Torque Specification Section of this publication.
Irregular tire wear	Worn spring eye bushing	Replace main support member.
	Loose spring eye bolt	Check frame hanger for and fasteners wear and replace as necessary.
Main support member broken between U-bolts	Loose U-bolts	Replace main support member and all mating parts.
Frame hanger worn	Loose fasteners and/or the re-use of old fasteners	Replace all worn parts and replace fasteners with new fasteners.

www.hendrickson-intl.com



Truck Commercial Vehicle Systems  
800 South Frontage Road  
Woodridge, IL 60517-4904 USA

1.866.755.5968 (Toll-free U.S. and Canada)  
1.630.910.2800 (Outside U.S. and Canada)  
Fax 1.630.910.2899